

OMSTAT ANTISTATIC BRUSHES

ANTISTATIC SOLUTIONS

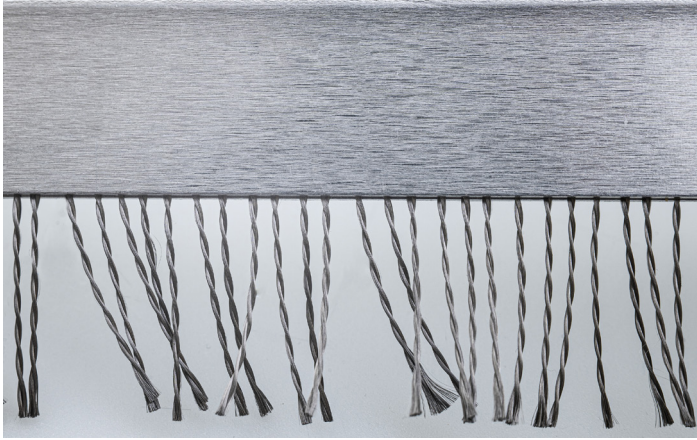
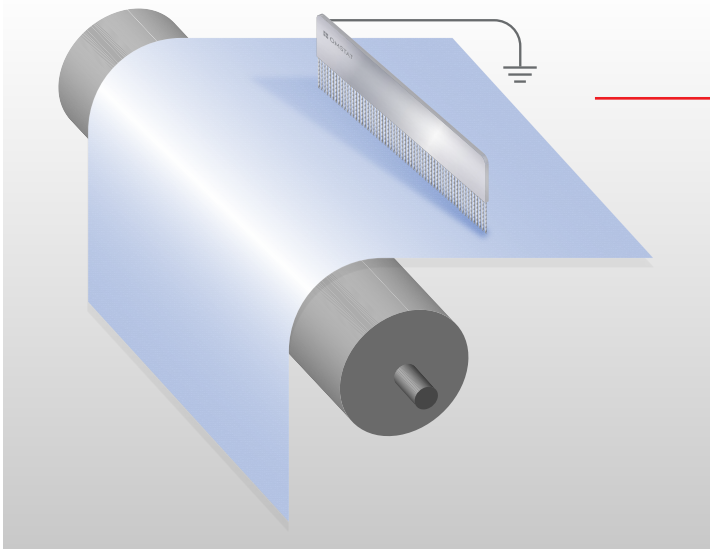

FIGURE A



Omstat strip antistatic brushes have carbon fibre and metal fibre bristles.

As long as the brush is in the proper position, both materials discharge static electricity very effectively. (See Figure A)
 The brush does not have to touch the surface; it can be 1 mm away from it.
 The charged material must be free from the other side, and the brush must not be placed near grounded metal parts.
 It is necessary to ground the brush.

FIGURE B

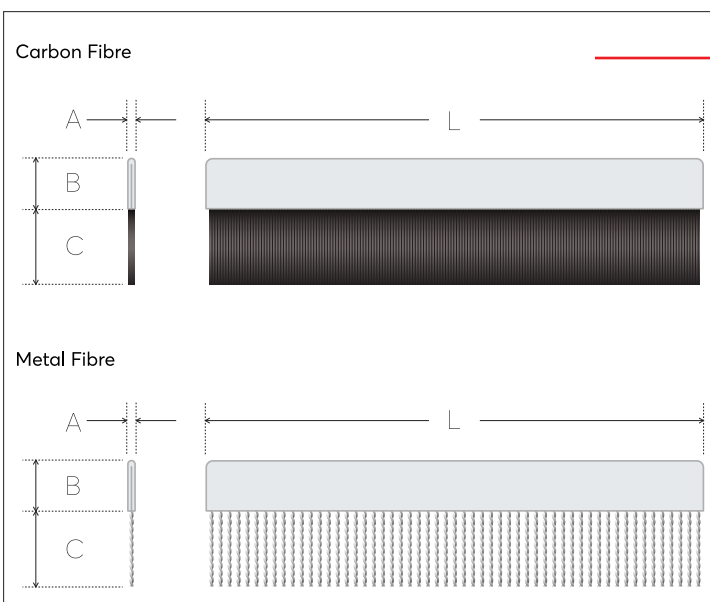

The following are the standard models (See Figure B)

L: length	1000mm
A: Aluminum thickness	2.2mm
B: Aluminum width	15mm or 20mm
C: Bristle length	18mm or 31mm

Metal fibre brush.
 Fibre diameter: 12 μ . 4-5 bristles per 10mm
Carbon fibre brush
 Fibre diameter: 6-8 μ . The carbon bundles are closely packed together with no gaps.



OMSTAT ANTISTATIC BRUSHES

ANTISTATIC SOLUTIONS



Antistatic Brush with Carbon fibre

L	B	C	P/N
1000 mm	15mm	21mm	ABCF1000 15 21
1000 mm	20mm	21mm	ABCF1000 20 21
1000 mm	15mm	31mm	ABCF1000 15 31
1000 mm	20mm	31mm	ABCF1000 20 31

Antistatic Brush with Metal fibre

L	B	C	P/N
1000 mm	15mm	18mm	ABMF1000 15 21
1000 mm	20mm	18mm	ABMF1000 20 21

Other sizes can be manufactured depending on volume

FIGURE C



The brush can be installed easily with the aid of an S-edge clip and an aluminum mounting bracket. (See Figure C)



CONTACT US

OMSTAT

Afroditi 1, P.O. Box 2856, GR 19400 Koropi Athens, Greece, Tel: +30 22910 70 832, Fax: +30 22910 70 897
Email: info@omstat.gr

Visit us to www.omstat-brushes.com

